

## Reguladora de Fluxo Cotovelo Metálica - Série SCL

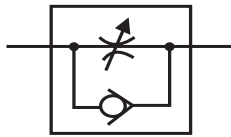

SCL -  
Modelo



Rosca	
M5	M5
01	1/8"
02	1/4"
03	3/8"
04	1/2"

Exemplo: SCL-01  
SCL-03

Características Técnicas					
Modelo	SCL-M5	SCL-01	SCL-02	SCL-03	SCL-04
Fluído	Ar				
Pressão de trabalho (Bar)	10				
Temperatura de trabalho (°C)	-5 à 80°C				
Vazão (l/min)	80	250	450	850	1600

## Dimensional

### SCL-01 / SCL-02 / SCL-03 / SCL-04

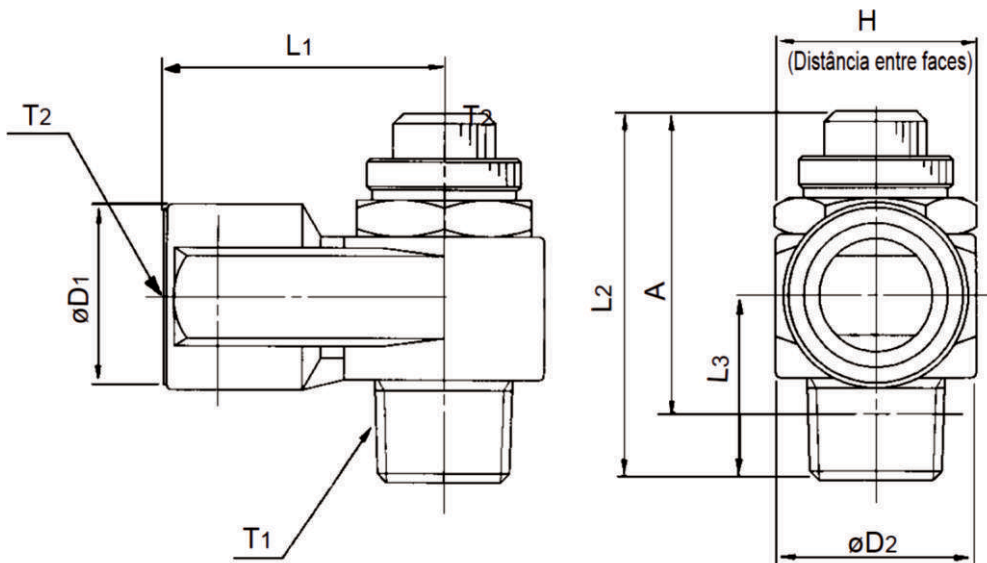

Modelo	T1	T2	H	L1	L2		L3	D1	D2	A	
					máx.	mín.				máx.	mín.
SCL-01	1/8"	1/8"	12	23	44.0	39.0	15.0	13.0	14.0	35.0	30.0
SCL-02	1/4"	1/4"	15	25.0	45.0	38.0	18	18	19.5	36.3	29.2
SCL-03	3/8"	3/8"	19	30	46.9	41.9	20.8	22.5	24.3	40.6	35.6
SCL-04	1/2"	1/2"	24	38.5	55.6	50.6	26.7	27.5	28.5	47.4	42.4