

- C

Ø Ext. do Tubo (mm)	
04	4
06	6
08	8
10	10
12	12

- C

Ø Ext. do Tubo (mm)	
04	4
06	6
08	8
10	10
12	12

Exemplo: VHK2-C06-C06
 VHK3-C08-C08
 VHK2-C10-C10

Características Técnicas	
Fluído	Ar
Pressão de teste (Bar)	15
Pressão de trabalho (Bar)	0 ~ 10
Temp. de trabalho (°C)	0 ~ 60
Material do corpo	Polibutileno tereftalato (PBT)
Vedação	NBR

Tamanhos Disponíveis					
Tubo (mm)	4	6	8	10	12
4	X	-	-	-	-
6	-	X	-	-	-
8	-	-	X	-	-
10	-	-	-	X	-
12	-	-	-	-	X

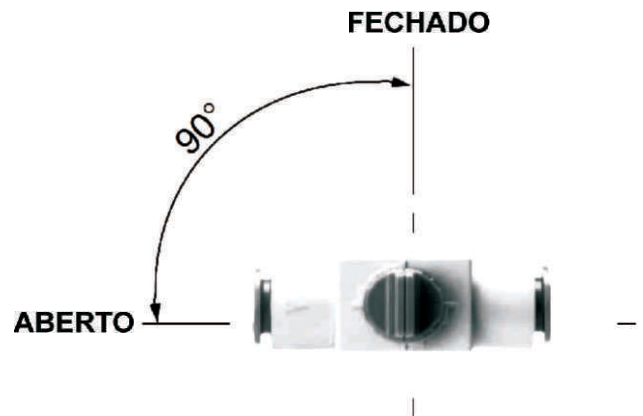
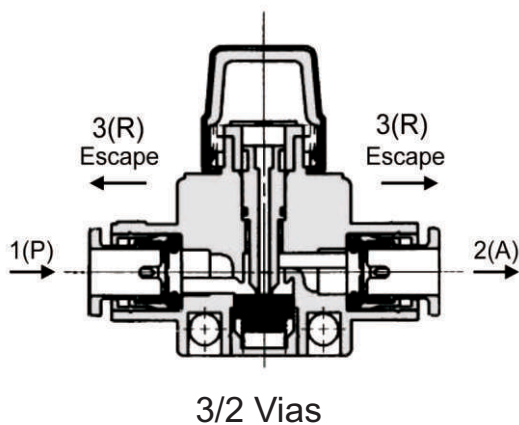
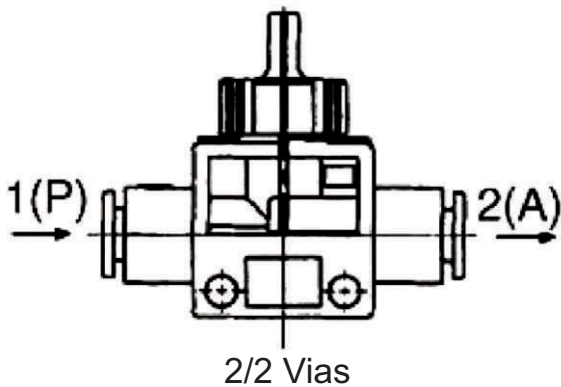



Dimensional

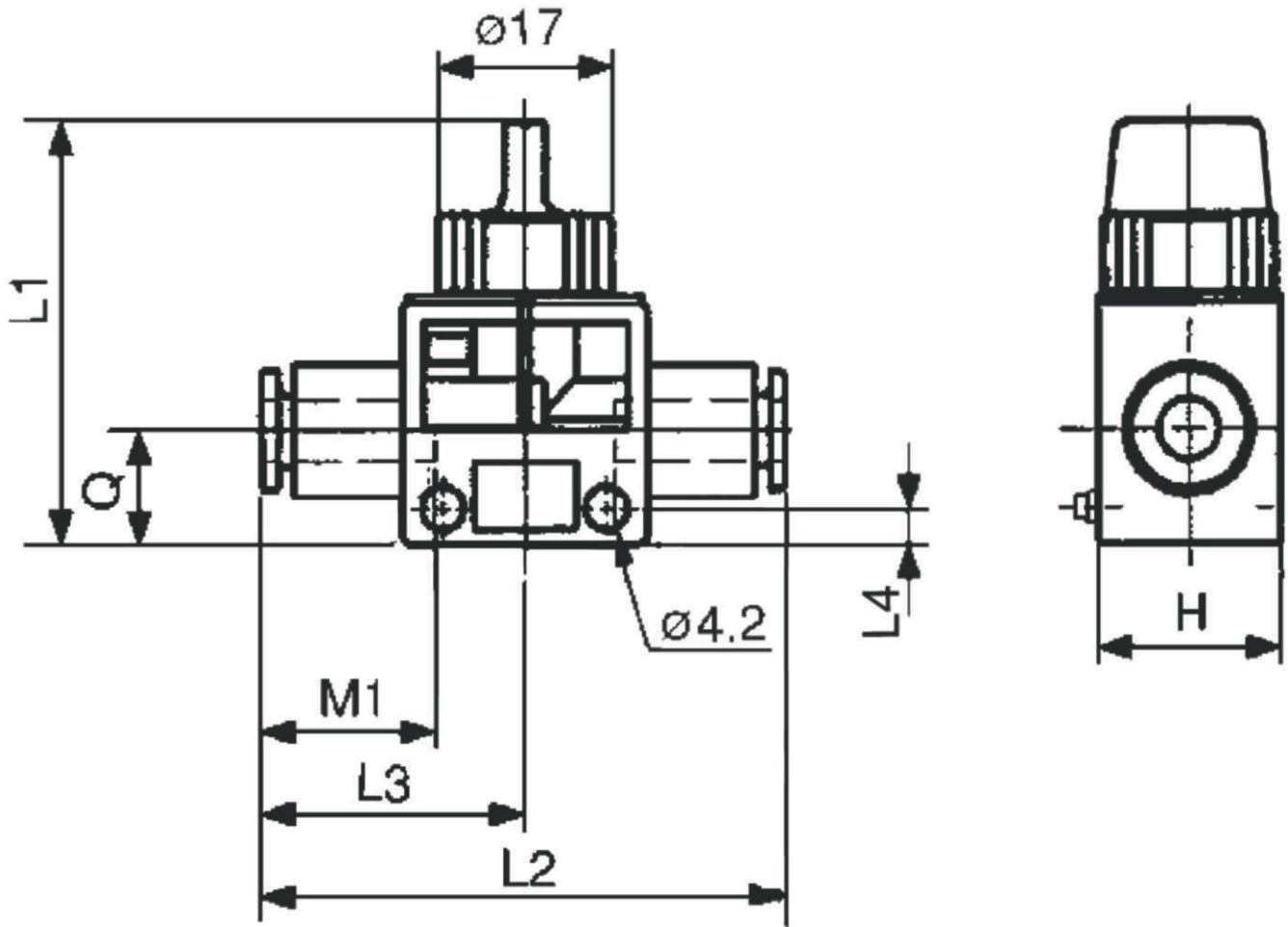

Modelo	Ø Tubo (mm)	Área Efetiva (mm ²)		H	L1	L2	L3	L4	M1	Q
		2/2 vias 1(P) → 2(A)	3/2 vias 2(A) → 3(R)							
VHK□-04-04	4	3.4	1.2	18	41	47.6	23.8	23.8	15.8	11
VHK□-06-06	6	7.2	1.2	18	41	48.6	24.3	24.3	16.8	11
VHK□-08-08	8	9.7	1.2	18	41	52.4	26.2	26.2	18.7	11
VHK□-10-10	10	16.7	3.2	22	46	61	30.5	30.5	20.8	14
VHK□-12-12	12	17.5	3.2	22	46	63	31.5	31.5	21.8	14